

NADY™
AUDIO

OWNER'S MANUAL



CMX-16A

16-CHANNEL STEREO MIC/LINE MIXER

CMX-16A

16-CHANNEL STEREO MIC/LINE MIXER



Congratulations on your choice of mixers — you have purchased one of the finest compact mixing consoles on the market today. This unit was developed using the expertise of professional sound engineers and working musicians. You will find that your new NADY AUDIO CMX-16A has superior performance and greater flexibility than any other mixer in its price range. Please read this manual carefully to get the most out of your new unit.

Thanks for selecting NADY AUDIO as your choice in mixing consoles.

Date of Purchase _____

Dealer's Name _____

City _____

State _____

Zip _____

Model # _____

Serial # _____

CONTENTS

WARNING	3
FEATURES	4
INSTALLATION	5
1. Inspection	5
2. Rackmounting	5
3. Power Connection.....	5
CONTROLS AND CONNECTIONS	6
1. Mono Input Section	6
2. Stereo Input Section.....	8
3. Master Section	9
a. Aux Sends>Returns Function and Operation	9
b. G1-2 Group Functions and Operation	10
c. Main Mix Function and Operation	10
d. Monitor Function and Operation	11
e. Power Switches	11
4. Connections	12
SPECIFICATIONS	13
BLOCK DIAGRAM	14

WARNING

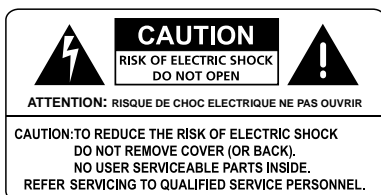

An equilateral triangle enclosing a lightning flash/arrowhead symbol is intended to alert the user to the presence of uninsulated "dangerous voltage" within the product's enclosure which may be of sufficient magnitude to constitute a risk of electric shock.



An equilateral triangle enclosing an exclamation point is intended to alert the user to the presence of important operating and service instructions in the literature enclosed with this unit.

IMPORTANT SAFETY INSTRUCTIONS

When using this electronic device, basic precautions should always be taken, including the following:

1. Read all instructions before using the product.
2. Do not use this product near water (e.g., near a bathtub, washbowl, kitchen sink, in a wet basement, or near a swimming pool, etc.).
3. This product should be used only with a cart or stand that will keep it level and stable and prevent wobbling.
4. This product, in combination with headphones or speakers, may be capable of producing sound levels that could cause permanent hearing loss. Do not operate for a long period of time at a high volume level or at a level that is uncomfortable. If you experience any hearing loss or ringing in the ears, you should consult an audiologist.
5. The product should be positioned so that proper ventilation is maintained.
6. The product should be located away from heat sources such as radiators, heat vents, or other devices (including amplifiers) that produce heat.
7. The product should be connected to a power supply only of the type described in the operating instructions or as marked on the product. Replace the fuse only with one of the specified type, size, and correct rating.
8. The power supply cord should: (1) be undamaged, (2) never share an outlet or extension cord with other devices so that the outlet's or extension cord's power rating is exceeded, and (3) never be left plugged into the outlet when not being used for a long period of time.
9. Care should be taken so that objects do not fall into, and liquids are not spilled through, the enclosure's openings.
10. The product should be serviced by qualified service personnel if:
 - A. The power supply cord or the plug has been damaged.
 - B. Objects have fallen into, or liquid has been spilled onto the product.
 - C. The product has been exposed to rain.
 - D. The product does not appear to operate normally or exhibits a marked change in performance.
 - E. The product has been dropped, or the enclosure damaged.
11. Do not attempt to service the product beyond what is described in the user maintenance instructions. All other servicing should be referred to qualified service personnel.

FEATURES



Offering up to 20 channels (including aux returns) plus 2 RCA tape inputs, this compact console and rackmountable mixer delivers top performance, full-functioned flexibility, and ultimate value and is ideal for even the most demanding mixing applications.

- Full frequency response, wide dynamic range and ultra low noise assures natural, transparent sound with maximum headroom
- 8 mono balanced (XLR and 1/4" TRS) and 8 stereo (1/4" TRS) inputs (16 total)
- L-R Main Mix and G1-2 Group Submix buses, with L-R, and G1-2 functions selectable on all channels and separately assignable to master mixes with separate master faders
- 2 Aux Sends and 2 stereo Aux Returns with Aux Send and Aux Return controls
- 8 mono input channel Inserts allow independent connection of effects devices for each mono channel
- Tape In and Record Out RCA jacks with Tape Input Level control
- Separate Control Room and Headphone Outputs
- PFL, L-R, and G1-2 mixes separately assignable to Headphone and Control Room outputs for versatile monitoring capability
- Input Trim controls on all channel inputs
- Balanced XLR and unbalanced 1/4" TRS Stereo Outputs
- 3-band EQ on all channels
- Tape In and Record Out RCA jacks with Tape inputs assignable to Master Mix or stereo Control Room/Headphone outputs
- Switchable +48V phantom power for all mono XLR Mic inputs
- Pan pots on each mono channel and Balance pots on each stereo channel
- 60 mm faders on all channels and master L/R and G1-2 bus mix for precise level control
- High quality sealed pots with center detents for all Pan/Balance and EQ controls
- Peak LEDs on all input channels
- Super accurate 10-stage LED display bargraph meters switchable to display L/R or G1/G2 mix levels
- High strength steel casing and superior construction with only highest quality components for longest life and maximum reliability. Rack ears for rackmounting supplied.
- External AC supply (PSU) for optimum signal integrity and superior transient response
- Dimensions & Weight: 15" x 17.5" x 3.75" (381 x 495 x 95 mm), 14.85 lbs (6.75 Kg)

INSTALLATION

To ensure years of enjoyment from your **NADY AUDIO CMX-16A** mixing console, please read and understand this manual thoroughly before using the unit.

1. INSPECTION

Your NADY AUDIO CMX-16A was carefully packed at the factory in packaging designed to protect the units in shipment. Before installing and using your unit, carefully examine the packaging and all contents for any signs of physical damage that may have occurred in transit.

[Please note: Nady Systems is not responsible for shipping damage. If your unit is damaged, do not return to Nady, but notify your dealer and the shipping company (if shipped to you) immediately to make a claim. Such claims must be made by the consignee in a timely manner.]

2. RACK MOUNTING

Enclosed in the shipping box you will find a rackmount kit. If you want to make your CMX-16A a rack mixer, remove the screws from the side panels and use them to fix the rack ears (note that there is a left and a right one).

Parts of the mixer and the power supply unit can become very warm during use. This is normal during operation. Care should be taken to ensure that there is enough space around the unit for cooling. Also, do not place the CMX-16A on high temperature devices such as power amplifiers etc. or the unit may overheat in operation.

Although the unit's chassis is shielded against radio frequency (RF) and electromagnetic interference (EMI), extremely high fields of RF and EMI should be avoided.

3. POWER CONNECTION

The CMX-16A is designed to operate with the supplied external power supply unit (PSU). Please make sure that the power unit supplied is marked for the correct voltage in your area (120VAC/60 Hz or 230VAC/50Hz). Power requirements for electrical equipment differ from area to area. In new installations and portable sound systems, or any situation in which the AC power is in question, it is wise to confirm the voltage and use the appropriate power supply unit before connecting it to power sources.

Check to see that the PSU is set to the voltage for your area by referring to the table below:

Europe (except UK): 230V, 50Hz
UK and Australia: 240V, 50Hz
USA and Canada: 120V, 60 Hz

For other areas, please check with local authorities.

Do not connect the PSU to the CMX-16A while the PSU is connected to the AC mains supply. Connect the switched-off CMX-16A and PSU first before you connect the PSU to the mains supply. Lastly switch on the CMX-16A with the power switch on the front panel. Use only the correct NADY power supply unit to connect the CMX-16A to the Mains AC power.

CONTROLS AND CONNECTIONS

1. MONO INPUT SECTION

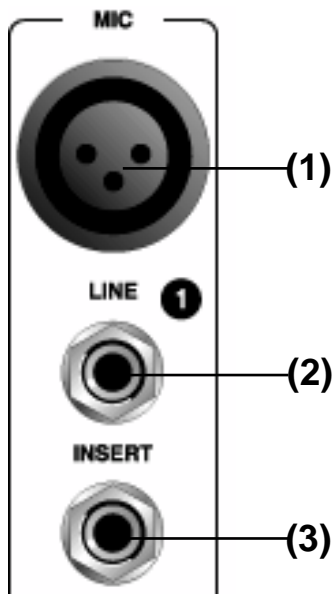

(1) MIC INPUT

The Mic input is an electronically balanced XLR type designed to accept signals from any balanced low impedance (Low Z) microphone. To accommodate condenser microphones, this input is also equipped with +48VDC phantom power globally switchable to all XLR input jacks with the **Phantom Power switch (27)** in the Master Section. Dynamic or ribbon-type microphones do not require phantom powering. It will be necessary to adjust the channel gain with the input **Trim control (4)** to achieve

a nominal operating level. The XLR jack is configured for: Pin1 = ground, Pin2 = positive (+), Pin3 = negative (-).

[Note: The Mic inputs are more sensitive than the Line inputs. Also, do not connect mics with the phantom power switched on, as indicated by the **Phantom Power On LED (27A)** next to the Phantom Power switch. Never use unbalanced mic cables with the Phantom Power switched on. Never short the +48VDC to ground, as that can cause serious damage to your mixer. Also, mute the Monitor/PA speakers when turning the phantom power on or off.]

(2) LINE INPUT

The Line input is designed to accept balanced or unbalanced line-level signals such as those from keyboards, drum machines, or samplers. There is enough gain available on the line input to accept even lower level signals, such as those from an unbalanced microphone or guitar output. Use the **Trim control (4)** to adjust for the desired level. If a balanced signal is to be connected to the line input, then a 1/4" TRS (stereo) phone plug should be wired for: Tip = positive (+), Ring = negative (-), Sleeve = ground.

(Note: Only either the Mic or the Line input of a given channel can be connected at one time. Never connect both simultaneously to the same channel.)

(3) INSERT

Channels 1-8 are equipped with insert jacks to connect external signal processors, such as compressors, noise reduction systems, or effects devices, to the individual input channels. Insert points are useful for adding dynamic processing or equalization to a channel or the mix. Unlike reverbs, etc., which are usually added to the dry signal, dynamic processing is normally applied across an entire signal. Here an Aux Send would be inappropriate. Instead the signal is intercepted somewhere along the channel, fed through the dynamics

processor and/or EQ, then returned to the console at the same point where it left. The insert point is normalized, i.e. the signal is only interrupted when a plug is plugged into it. The insert jack is located pre EQ in the channel and is configured as: Tip = send, Ring = return, Sleeve = ground. The Insert can also be used as a channel direct output by sending the signal from the ring. To use the Insert as a direct output, insert a 1/4" phone plug halfway into the Insert jack so the tip of the plug connects with the ring of the insert jack. The jack will click into place when the connection to the ring is made.

(4) TRIM CONTROL

The trim control adjusts the input sensitivity (channel gain) of the mic and line inputs on channels 1 through 8. This control can be adjusted to accommodate input signals from a wide variety of sources, from the high outputs from keyboards or drum machines to the small signal outputs of microphones. This wide range eliminates the need for Mic/Line switching. The best balance of S/N and dynamic range will be achieved if you adjust the TRIM control on each channel separately so that the **Peak Indicator LED (8)** for that channel lights occasionally.

(5) EQUALIZER CONTROLS

All mono input channels are fitted with a three-band EQ. All three bands have up to 15 dB of cut and boost, with a center detent for "off". The frequency response is flat when all three EQ knobs are in the center detent position. The upper and lower shelving controls have their frequencies fixed at 12 kHz and 80 Hz respectively. The midrange control has a peaking response at 2.5kHz (Q fixed at 1 octave). The channel EQ is an important part of the mixer as it allows the user to control the tonal characteristics of each instrument separately. For example, boosting the LOW can fatten the sound and add punch to the bass or drums; the MID control can be used to define the midrange or bring out the vocals; and adjusting the HIGH control can provide a crisp sounding high end. A very important, yet often overlooked technique is to use the EQ to subtract from the mix. Cutting the HIGH control can reduce unwanted hiss during multi-track recording, while attenuating the MID or LOW can eliminate feedback in a live performance or clear up a muddy sounding mix.

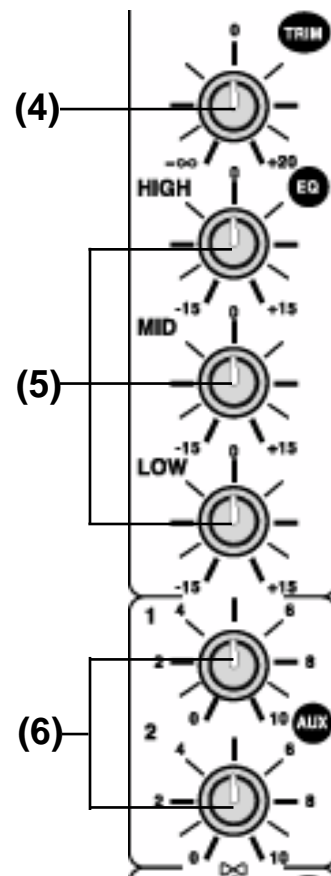

CONTROLS AND CONNECTIONS

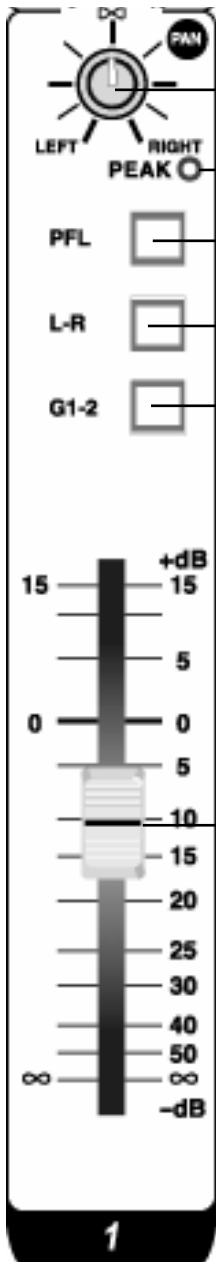

(7) [Note: Always reset a channel's input Gain (or external devices' output level) after altering the amount of mixer equalization cut or boost applied.]

(8) The key to successful equalization is to avoid excess. Too much equalization on the input channels will result in a mix that is smeared together with nothing specifically defined. During rehearsals, experiment with the equalizer controls on various instruments, vocals and combinations of these mixed together to become familiar with various equalizer settings.

(6) **AUX SEND 1, 2 CONTROLS**
Both Aux Sends are mono and post-EQ and control the level of the signals sent to the AUX buses.

- Aux Send 1 is pre-fader and the signal sent to the AUX 1 bus will be unaffected by the channel fader setting.
- Aux Send 2 is post-fader and the signal level sent to the AUX 2 bus will be affected by the channel fader setting.

(12) For almost all effects send purposes, you will want to use the post-fader AUX 2, so that when a fader level is adjusted, any reverb send from that channel follows the fader. Otherwise, when the fader is pulled down, the reverb from that channel would still be audible. Most reverbs etc. internally sum the left and right inputs so that you can use AUX 2. You can also use this AUX 2 send to feed inputs to a multi-track recorder or any other unbalanced line level application. On the other hand, for cueing purposes and monitor amplifiers, use the pre-fader AUX 1 (i.e. independent of the channel fader)

mines the stereo position of any signal routed to the G1-2 bus, when G1-2 bus is selected with the **G1-2 button (11)**.

(8) **PEAK LED INDICATOR**
The Peak LED illuminates when a channel is going into overload. It detects the peak level after the EQ and will light at 3dB before clipping to warn that the signal is approaching overload. You do not want the Peak LED to light except very intermittently during a take or a mix. If it does light persistently, reduce input gain with the **TRIM control (4)**.

(9) **PFL SELECT SWITCH**
The PFL (pre-fader listen) switch enables monitoring the mono signal of any channel(s) selected (button depressed) at nominal levels though the headphone or control room monitor outputs. The signal is post EQ and independent of channel fader position. Selecting the PFL never interrupts the main stereo out or the AUX sends.

(10) **L-R SELECT SWITCH**
When the L-R switch is selected (button depressed), the post fader channel signal is fed to the master L-R faders.

(11) **G1-2 (GROUP) SELECT SWITCH**
The G1-2 switch enables selecting (button depressed) the channel for routing to the G1-2 stereo bus, controlled by the master G1-2 fader. This signal is post channel fader and the stereo placement is adjusted by the Pan control. The G1-2 Group bus offers you a second stereo submix with its own stereo G1-2 submaster fader. It can be used as a convenient mixing aid both live and in the studio; for example, to combine the outputs of all drum channels onto just 1 or 2 submaster faders, or to route to multi-track recorders. You can generate two mono subgroups in addition to the normal Main Mix stereo bus by patching the G1 and G2 OUT back into two mono channels, and use these as Subgroup masters

(Note: the subgroup return channels must not be routed to the G1-2 bus themselves, by depressing their G1-2 select switch, as that would result in a feedback loop).

(12) **CHANNEL FADER**
The channel faders determine the output signal level to the Master Mix or G1-2 buses. They offer a smooth logarithmic taper more often associated with much more expensive consoles for optimum control of the signal.

(7) **PAN CONTROL**
The Channel Pan positions the output of the channel in the stereo field of the main mix if the **L-R Select switch (10)** is depressed. Its constant-power design ensures there are no level discrepancies whether a signal is hard-panned, center-stage, or somewhere in-between. Channel Pan also deter-

CONTROLS AND CONNECTIONS

2. STEREO INPUT SECTION

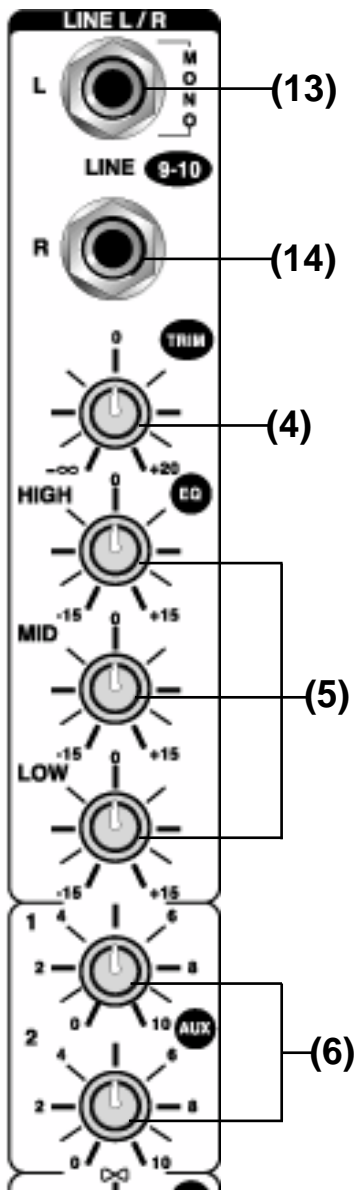

(13) L (MONO) LINE INPUT

On stereo input channels 9-16, the 1/4" line inputs are designed for stereo or mono line-level signals such as those from keyboards, drum machines, CD players, tape decks, or samplers.

However, these inputs can also be used as standard mono line inputs by connecting the signal to the L (MONO) line in. This signal will be routed equally to the BAL control and the left and right outputs in the same way as the standard line input channels. For the stereo line inputs the mono channel **PAN (7)** control is replaced by the BAL control. See also **BAL CONTROL (15)** above.

(14) R LINE INPUT

When using channels 9-10, 11-12, 13-14, or 15-16 as stereo input channels, the left signal should be connected to the L input and the right signal to the R input. These signals will be routed to the AUX, EQ and Channel fader controls equally and will retain their stereo separation. The AUX, EQ, BAL, and Channel fader controls all function the same as

those on mono input channels 1-8.

When a stereo signal is input to a stereo input channel, these controls will affect the left and right signals equally. The Stereo Line Input jacks are 1/4" TRS balanced phone jacks, Tip = positive (+), Ring = negative (-), Sleeve = ground.

(4) TRIM CONTROL

The stereo Trim control operates in the same manner as the mono Trim control. The stereo inputs are designed for any line level signal. Most line level sources such as MIDI instruments and effects units will have their own output level control. However any added adjustment necessary for proper leveling can be done with the Trim control.

(5) EQUALIZERS

The stereo channel EQ's operate in the same manner as those in the mono channels. The left and right signals will be affected equally. A stereo equalizer is generally preferable anyhow to using two mono equalizers when equalizing a stereo signal as it avoids possible discrepancies between the left and right settings.

(6) AUX SENDS

These are the same as for the mono channels. Note that a mono sum is taken from the stereo input.

(15) BAL CONTROL

For a mono input to the L(MONO) input the function of the control is the same as the **PAN (7)** controls of the mono channels. However, when a channel is run in stereo, this control functions as a Balance control, determining the relative Balance of the left and right channel signals being sent to the left and right Master Mix buses. For example, with the Balance control turned fully clockwise, only the right portion of the channel's stereo signal will be routed to the Master Mix. Balance also determines the relative amount of left and right channel signals being sent to buses G1, G2 respectively when the **G1-2 Select switch (11)** is engaged.

(8) PEAK LED INDICATOR

(9) PFL SELECT SWITCH

(10) L-R SELECT SWITCH

(11) G1-2 (GROUP) SELECT SWITCH

(12) CHANNEL FADER

This has the same function as for the mono channels. See **MONO INPUT SECTION**.

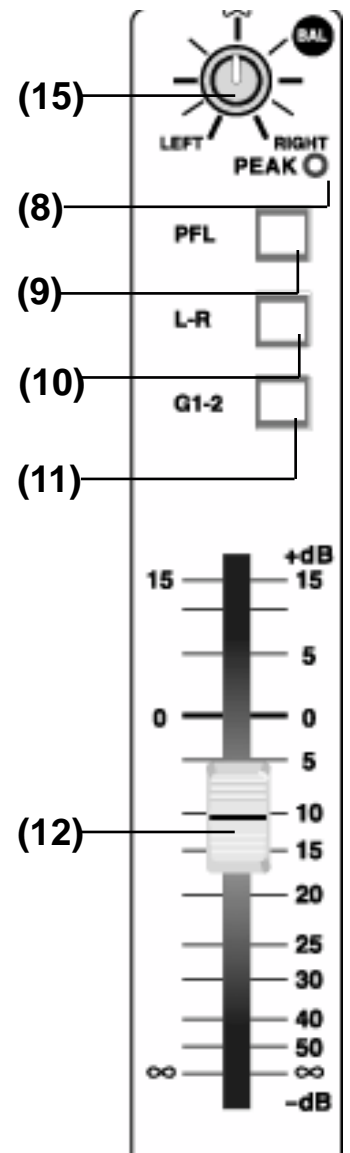

CONTROLS AND CONNECTIONS

3. MASTER SECTION

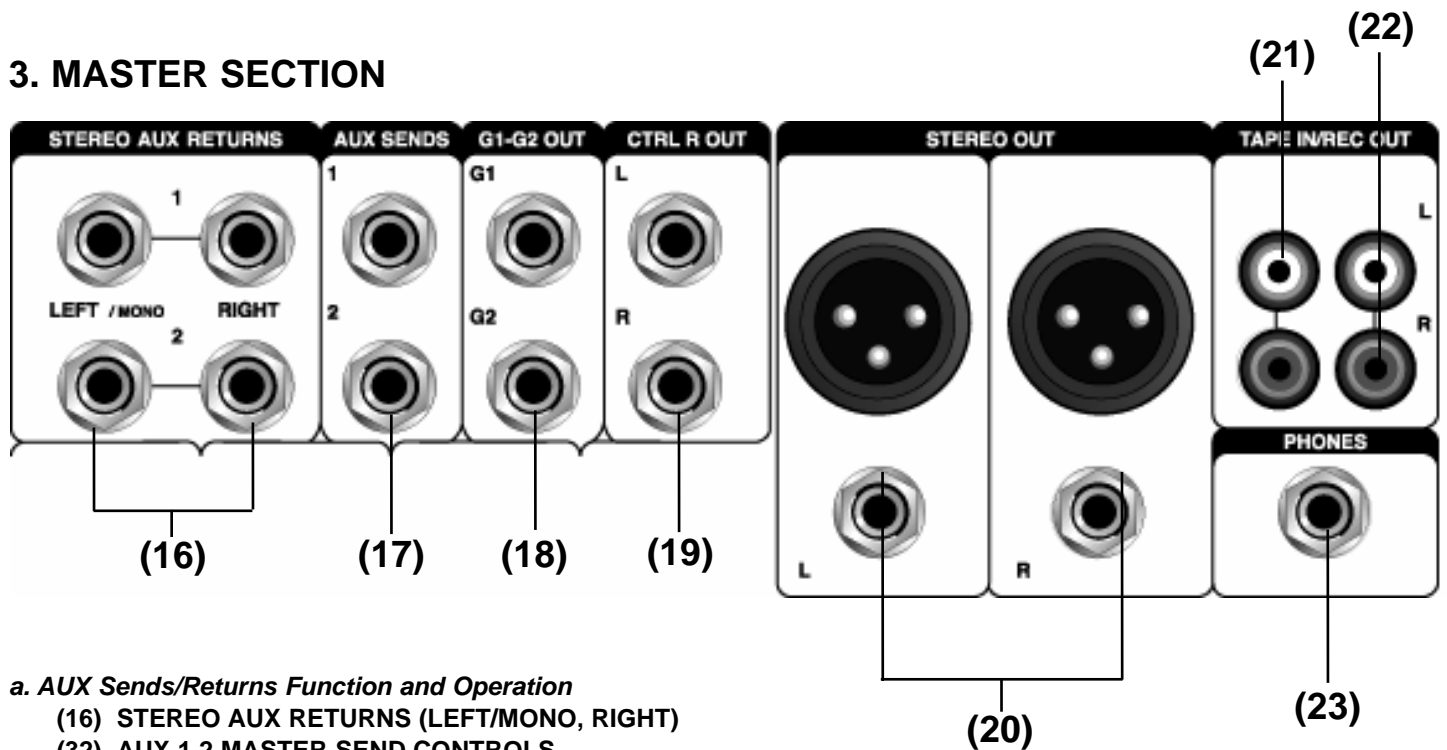

a. AUX Sends>Returns Function and Operation

- (16) STEREO AUX RETURNS (LEFT/MONO, RIGHT)
- (32) AUX 1,2 MASTER SEND CONTROLS
- (36) AUX 1,2 RETURN CONTROLS
- (37) AUX RETURN BALANCE CONTROLS
- (38) L-R AUX RETURN ASSIGN SWITCH
- (39) G1-2 AUX RETURN ASSIGN SWITCH

The AUX Return jacks are the mono or stereo returns for AUX 1 and 2. If you connect a signal to the Left/Mono Return jack only, the AUX Return will operate in mono and the signal will be routed to the respective **Aux Return Control (36)** and then mixed into the left and right **Main Mix Stereo Outputs (20)** and/or **G1-G2 Outputs (18)**, depending on whether you selected either or both outputs with the **L-R (38)** or **G1-2 (39) AUX Return Assign** switches. The separate left and right return jacks are provided for use with stereo signals such as those from the output of a stereo effects processor. The left and right return signals will be routed to the return **level controls (36)** and mixed into the left and right **Stereo (20)** or **G1-G2 (18) Outputs** separately [depending on the outputs selected with the **AUX Return Assign switches (38,39)**], while maintaining stereo separation. Use the **AUX Return Balance Controls (37)** to adjust the balance of the AUX Return signal.

For example, if these knobs are turned all the way to the left, the signal will be sent only to the L and/or G1 bus, and turned all the way right, only to the R and/or G2 bus, and in the center equally to both the L, R, and/or G1, G2 buses [again depending on the outputs selected with the **AUX Return Assign switches (38,39)**]. The Aux Returns are multi-functional. They may be used for returning the outputs of effect units, as Tape Returns from a multi-track recorder, or as extra instrument inputs, especially if your MIDI keyboard or rack supplies a pre-mixed stereo signal.

Certain stereo effects produce a perceived imbalance between the left and right channel levels. To correct for this you will have to bring your stereo effect back on a stereo channel, which has a **Balance control (15)**. When applying short left and right delays, the shortest one will always seem loudest. When pitch shifting up and down in wide stereo to thicken a sound, the signal shifted upwards will seem louder than one that goes down. In both cases use the Balance control to compensate. When performing any stereo imaging exercise, don't just rely on the control room monitors. Get a pair of headphones and listen in stereo and in reverse stereo, just in case you have any significant hearing discrepancies. Sometimes you might want to narrow the stereo width of a reverb field. To do this you will have to come back on two mono channels to get independent pan for the left and right signals.

(17) AUX SENDS

The Aux Send 1 and 2 jacks are the outputs for the signals sent from the channel Aux controls (6). They are 1/4" unbalanced phone jacks wired: Tip = positive (+), Sleeve = ground.

AUX 1 is pre-fader and AUX 2 is post-fader. These signals can be sent to the input of an effects processor, multi-track recorder, or used for any other line-level auxiliary purpose. Master Aux Send levels are adjusted by the **Aux Master Send controls (32)**.

CONTROLS AND CONNECTIONS

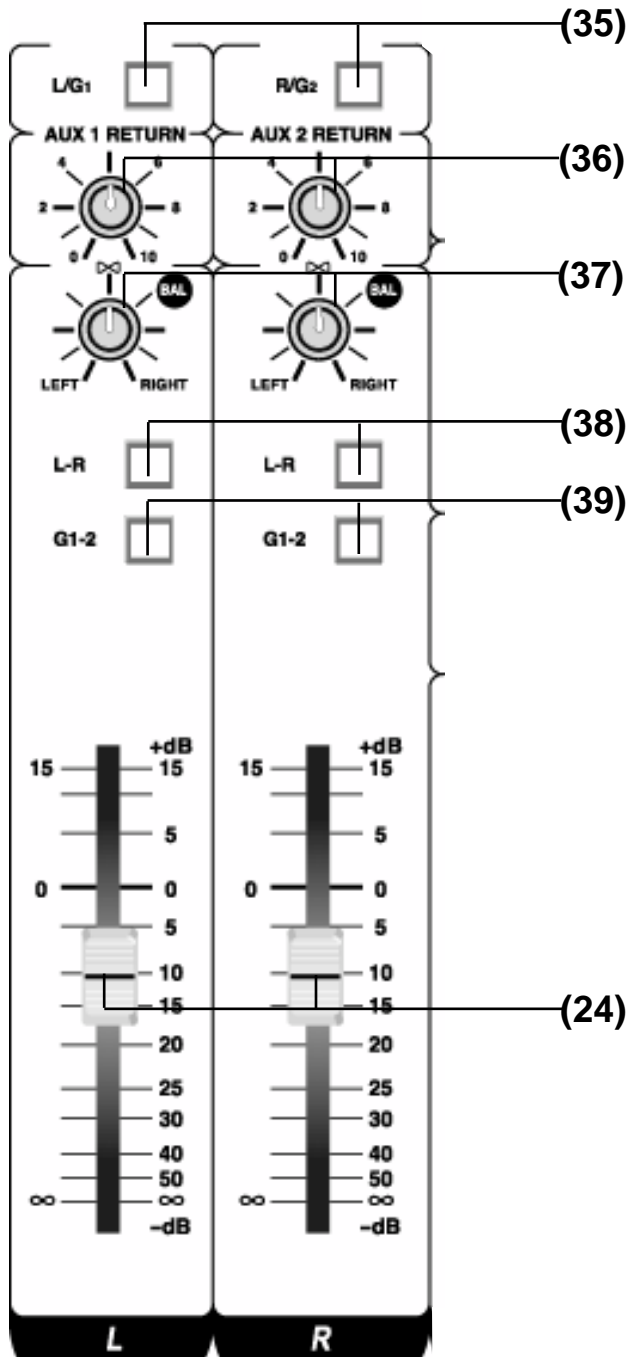
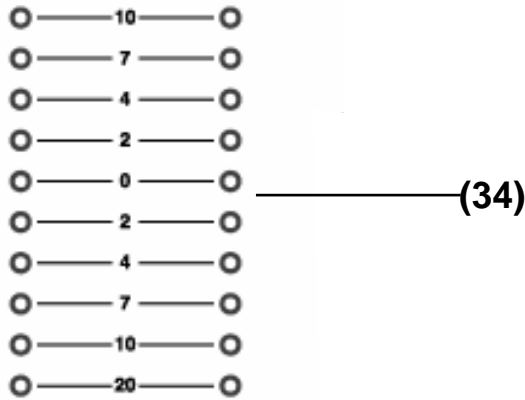

b. G1-2 Group Functions and Operation

- (18) G1-G2 OUTPUTS
- (25) G1-2 MASTER FADER
- (31) G1-2 MONITOR SELECT SWITCH
- (35) L/G1-R/G2 METER SELECT SWITCHES
- (39) G1-2 AUX RETURN ASSIGN SWITCH

A channel's output will be routed to the G1—G2 **Group Outputs (18)** by depressing the **G1-2 Select switch (11)**. These outputs are 1/4" TRS balanced phone jacks, wired: Tip = positive (+), Ring = negative (-), Sleeve = ground. Level to the G1-G2 Outputs is adjusted by the **G1-2 Master Fader (25)**. You can also monitor the G1-2 signal via **headphone (23)** or **control room (19)** outputs by the **G1-2 Monitor Select switch (31)**. The **G1-2 AUX Return Assign switches (39)** can be selected to route the AUX return signal to the G1-2 bus and the G1-2 **Master fader (25)**. The signal level of all signals on the G1-2 bus can be monitored by the 10-stage LED Output meter by selecting either or both G1 and G2 on the **Meter Select switches (35)**. The G1-2 Group can be a very useful feature if used effectively. Subgroups are commonly used as a mixing aid both live and in the studio. For example, you can combine the outputs from all drum channels onto just 1 or 2 submaster faders. They are also used to route to multi-track recorders. There are no dedicated subgroups on the CMX-16A. However, the G1-2 bus offers you a second independent stereo submix with its own submaster stereo fader. You can generate two mono subgroups in addition to the normal Master Mix stereo bus by patching G1-G2 Outputs back into two mono channels, and use these as Subgroup masters

(Note: The subgroup return channels must not be routed to the G1-2 bus themselves, as this would result in a feedback loop.)

c. Main Mix Function and Operation

- (20) STEREO OUTPUTS
- (21) TAPE INPUTS
- (22) REC OUTPUTS
- (24) L/R MASTER FADERS
- (33) TAPE IN LEVEL CONTROL
- (34) LED OUTPUT METER
- (35) L/G1-R/G2 METER SELECT SWITCHES
- (38) L-R AUX RETURN ASSIGN SWITCHES

The Stereo Outputs consist of both Left (L) and Right (R) balanced XLR's, wired: pin 1 = ground, pin 2 = hot (+), pin 3 = cold (-), and unbalanced 1/4" phone jacks, wired: Tip = positive (+), Sleeve = ground.

The **REC Outputs (22)** also provide an output of the Master Mix. These outputs are RCA jacks, and designed primarily for inputs to tape recorders, etc.

The output level routed to the Stereo Outputs and REC Outputs is determined ultimately by the setting of the **L,R Master Faders (24)**. The Master Mix (signal on the master bus) is the sum of the signals routed from all the channels and also the inputs from the AUX return bus (if either or both the **L-R AUX Return**

CONTROLS AND CONNECTIONS

Assign switches (38) are depressed) and the TAPE Input. The level of signal routed to the L-R Master faders (24) from tape decks, CD players, etc., input to the Tape Input (21) is determined by the Tape In Level Control (33). The 10-stage LED Output Meter (34) can be selected with the Meter Select Switches (35) to display the Master Mix output level.

d. Monitor Function and Operation

- (19) CONTROL ROOM OUTPUTS
- (23) HEADPHONES OUTPUT
- (28) PHONES/CONTROL ROOM CONTROL
- (29) PFL MONITOR SELECT SWITCH
- (30) L-R MONITOR SELECT SWITCH
- (31) G1-2 MONITOR SELECT SWITCH

The CMX-16A allows you to monitor singly the L-R Main Mix, the G1-2 Group mix or the pre-fader PFL signal by selecting one of the appropriate Monitor Select switches (29,30,31). The level of the selected signals is adjusted with the Phones/Control Room control (28) and routed to both the Control Room (19) and Headphones (23) outputs. The L-R Control Room Outputs (19) can be connected to an amp to power stereo control room (or other) monitor speakers and are 1/4" unbalanced phone jacks, wired: Tip = positive (+), Sleeve = ground. The Phones Output will feed headphones and is a 1/4" TRS jack, wired: tip = left signal, ring = right signal, sleeve = ground.

e. Power Switches

- (40) AC POWER IN SOCKET
- (26) MAIN POWER SWITCH
- (26A) POWER ON LED INDICATOR

Once the external PSU is connected to the AC Power In Socket (40) and then to the AC power source, you may switch on your mixers with the Power On switch (26). The Power "ON" LED (26A) will light up. Allow 1 minute after powering up for the system to reach equilibrium before setting inputs gains and other levels.

- (27) PHANTOM POWER SWITCH
- (27A) PHANTOM POWER ON LED INDICATOR

When using condenser mics, +48VDC can be switched globally on or off to the XLR mic inputs for all mono channels (also see MONO INPUT SECTION, MIC INPUTS). When this switch is in the "ON" position, The Phantom Power On LED Indicator (27A) will light, and +48VDC will be provided between pins 2 and 3 of all the mono Mic input XLR connectors (Ch 1-8). If you don't need phantom power, be sure to turn this switch to the "OFF" position.

[Note: It is safe to connect balanced dynamic mics or line level devices even if this switch is on, but connecting unbalanced devices or devices whose transformers are center-grounded will cause hum or malfunctions. Shorting the +48VDC can also damage your mixer. Also, mute the Monitor/PA speakers when turning the phantom power on or off.]

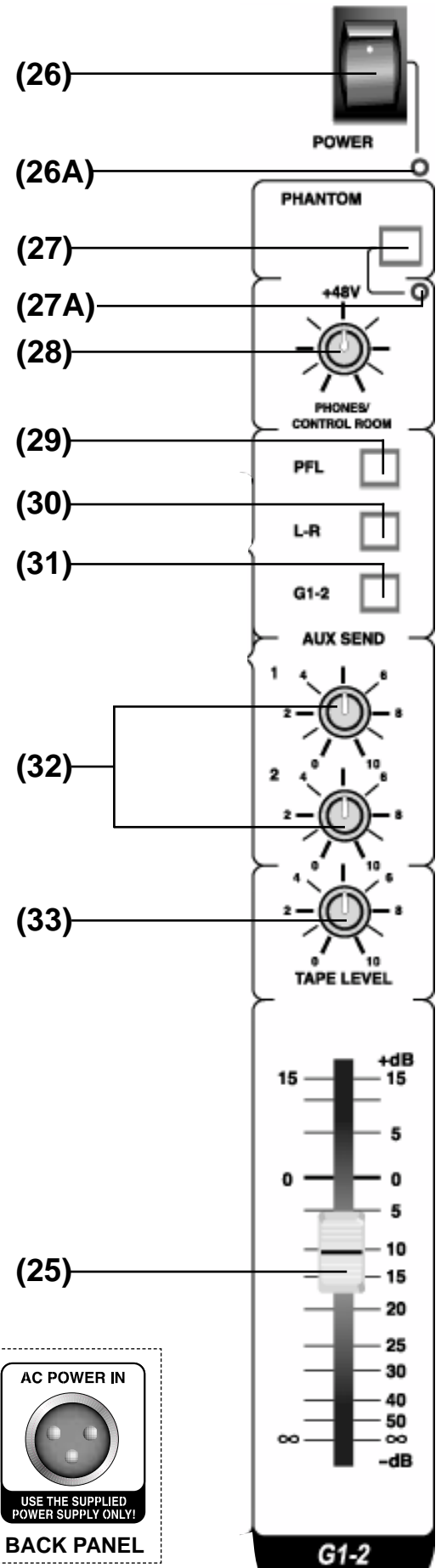

(40)

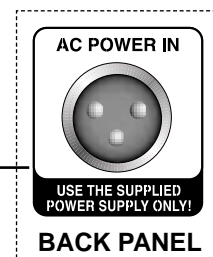

CONNECTIONS

This NADY AUDIO console uses 4 different types of audio connectors for the various input/output connections: (1) XLR balanced; (2) 1/4" TRS phone jacks for balanced, unbalanced, stereo, or in/out inserts; (3) 1/4" TRS unbalanced; (4) RCA pin unbalanced

Figures

1. *Balanced XLR input/output connections*
2. *Stereo headphone connection with 1/4" TRS plug*
3. *1/4" mono (TRS) plug used as unbalanced input/output*
4. *1/4" stereo (TRS) plug used as balanced input/output*
5. *1/4" TRS plug used as Insert Send/Return*
6. *RCA pin plug for unbalanced input/output*

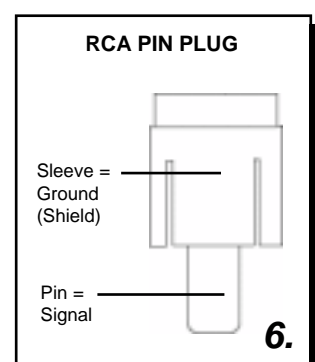
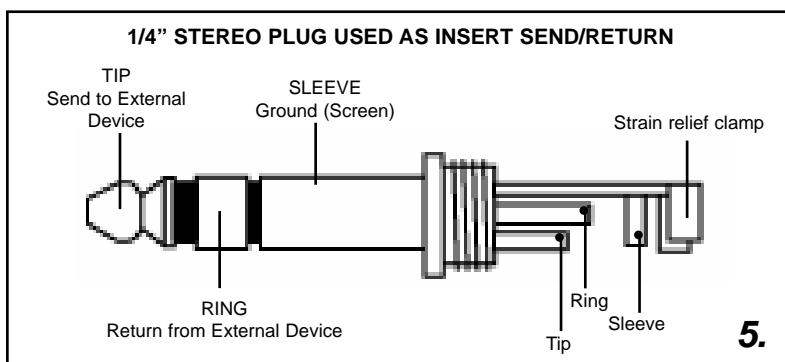
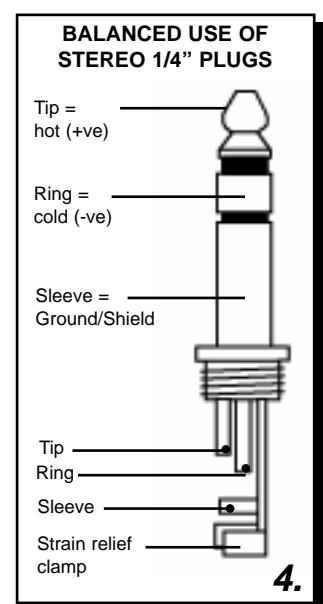
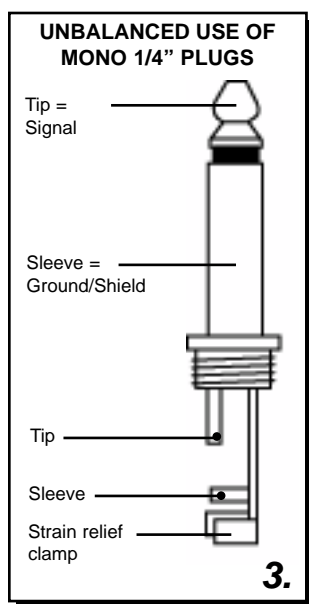
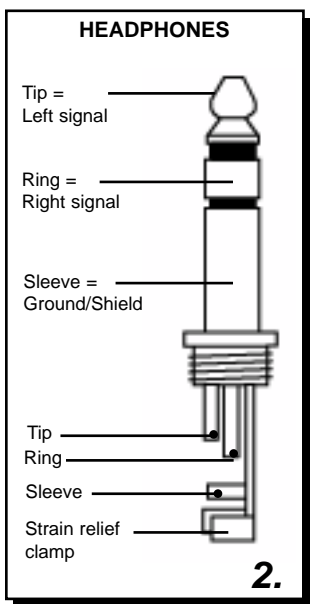
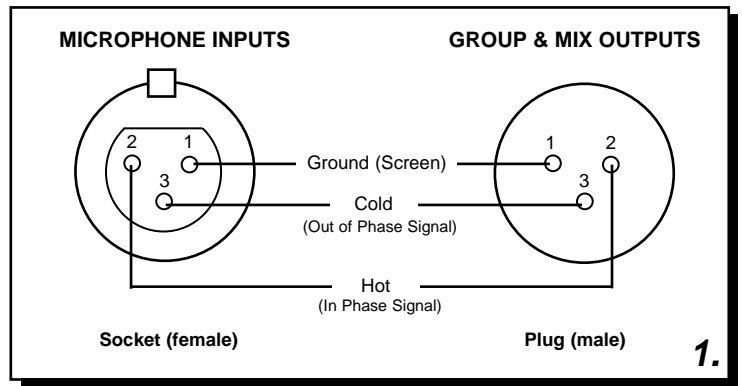

SPECIFICATIONS

1. INPUT SECTION

Input	Connector	Input Impedance	Nominal Level	Max Level
MONO CH MIC	XLR	>1.3K Ω	+2 dBm	+14 dBm
MONO CH LINE	1/4" TRS	>10K Ω	+4 dBm	+22 dBm
STEREO CH LINE	1/4" TRS	>10K Ω	+4 dBm	+22 dBm
TAPE IN	RCA PIN JACKS	>10K Ω	+2 dBm	+22 dBm
AUX RETURNS	1/4" TS	>10K Ω	+4 dBm	+22 dBm
INSERT IN	1/4" TRS	>10K Ω	+4 dBm	+22 dBm

2. OUTPUT SECTION

Output	Connector	Output Impedance	Nominal Level	Max Level
STEREO OUT L/R	XLR & 1/4" TS	120 Ω	+4~+6 dBm	+22 dBm
AUX SENDS 1,2	1/4" TS	120 Ω	+4~+6 dBm	+20 dBm
G1-G2 OUT	1/4" TRS	120 Ω	+4~+6 dBm	+22 dBm
INSERT OUT	1/4" TRS	120 Ω	+4~+6 dBm	+22 dBm
CNTRL R. OUT	1/4" TS	1K Ω	+4~+6 dBm	+22 dBm
REC OUT	RCA PIN JACKS	1K Ω	+4~+6 dBm	+22 dBm
PHONES	1/4" TRS	200 Ω	—	40mW X 2

3. FREQUENCY RESPONSE

ANY INPUT TO
 ANY OUTPUT20 Hz to 20 KHz \pm 3dB @ 0 dBm

4. TOTAL HARMONIC DISTORTION

ANY INPUT TO
 ANY OUTPUT0.02%, 20 Hz-20 KHz @ 1Khz, 0 dBm

5. INPUT CHANNEL EQUALIZATION

High shelving12 kHz, \pm 15 dB, Q fixed at 2 oct.
 Mid bell2.5 kHz, \pm 15 dB, Q fixed at 1 oct.
 Low shelving80 Hz, \pm 15 dB, Q fixed at 2 oct.

6. GAIN CONTROL RANGE

Input channel trim control....Stop to stop- Mic +10 dB~+60 dB,
 Line+10 dB~+40 dB
 Channel/Master Faders - ∞ to +15 dB
 Aux Send/Aux Master SendOff to +15 dB
 Aux ReturnOff to Unity to +20 dB
 Tape In Level ControlOff to +15 dB

7. CROSSTALK @ 1KHZ

ADJACENT CHANNEL INPUTS-78 dB~-68 dB
 INPUT TO OUTPUT -78 dB~-68 dB

8. HUM AND NOISE

20 Hz-20 KHz, $R_s=150$ ohms, input TRIM @ 0 dB, input sensitivity at -60 dB
 EQUIVALENT INPUT NOISE-129 dBm
 RESIDUAL OUTPUT NOISE.....-85 dBm

9. VU METERS

10-segment LED X 2, L/G1, R/G2

10. PHANTOM POWER

+48 VDC, globally selected

11. POWER REQUIREMENTS

External PSU, 120 VAC/60Hz or 230 VAC/50Hz

12. POWER CONSUMPTION

40 Watts, External PSU

13. DIMENSIONS AND WEIGHT

15" x 17.5" x 3.75" (381 x 495 x 95 mm), 14.85 lbs (6.75 Kg),
 External PSU not included

The specifications above are correct at the time of printing of this manual. For improvement purposes, all specifications for this unit, including design and appearance, are subject to change without prior notice.

BLOCK DIAGRAM

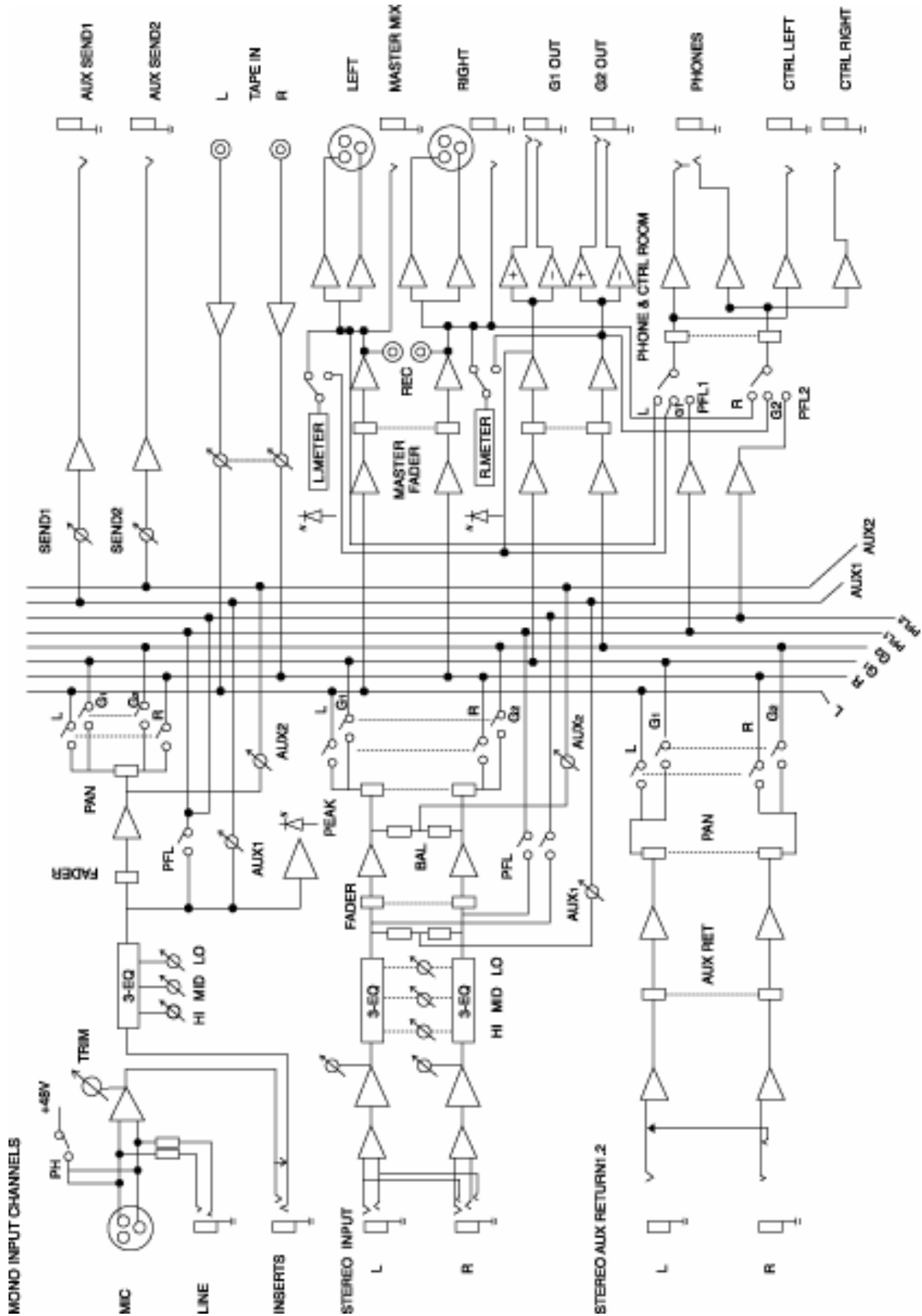

SERVICE FOR YOUR NADY AUDIO PRODUCT

(U.S.) Should your NADY AUDIO product require service, please contact the Nady Service Department via telephone at (510) 652-2411, or e-mail at service@nadywireless.com.

(International) For service, please contact the NADY AUDIO distributor in your country through the dealer from whom you purchased this product.

DO NOT ATTEMPT TO SERVICE THIS UNIT
YOURSELF AS IT CAN BE DANGEROUS
AND WILL ALSO VOID THE WARRANTY.

